

## 注塑用机械手 TAKE-OUT ROBOT

**EU-80  
EU-80s**



### 标准功能 STANDARD FUNCTION

装箱动作 (各轴256点)  
Packaging motion (Max. 256 points)

自由装箱点 (115点 × 2处)  
Free packaging motion (115points × 2stage)

取出侧前进姿势控制  
Forward and rotate at removing side

走行途中姿势  
Posture control during traverse

落下测下降途中姿势  
Posture midway descent at release side

顶针连动  
Ejector link

不良品排出回路  
Defective product reject circuit

初期不良品排出回路  
Initial defective product reject circuit

取向下降待机  
Delayed arm descent

胶口途中开放 (去程, 返程)  
Midway runner release (Move, Revert)

水口模内开放  
Runner release within mold

吸着确认单元 (2回路)  
Additional vacuum sensing unit (2 circuit)

横走行待机  
Delayed traverse

滑移取出回路  
Undercut extract circuit

输送带启动信号  
Start signal of conveyor

内部存储记忆 (最大100种类型)  
Internal memory (for Max 100 molds)

设定值锁定功能  
Lock function of setting value

固定可动切换  
Extraction from fixed mold

2国语言切换 (中文, 英文)  
Two language exchange (Chinese/English)

型式 MODEL	单位 UNIT	EU-80	EU-80s
电源 Power Source	V	AC 200~220 ± 10% 50/60Hz	
最大消费电力 Max Power Consumption	KW	2	2.8
使用气压 Air Pressure	Mpa	0.5~0.7	
空气消费量 Air Consumption	Nl/cycle	2.9	
驱动方式 Drive System	---	伺服马达 / AC Servo Motor	
姿势 (气缸) Posture (Air Cylinder)	---	90°固定 / 90°Fixed	
■ 气缸推力 (气压0.49MPa时) Air Cylinder Driving Force (Air Pressure at 0.49MPa)			
最大可搬重量 Max.Load	Kg	6 【含夹具重量 / Incl Chuck Weight】	
姿势力矩 Posture Torque	N · m	11.7	
■ 行程 Stroke			
主臂上下 Main-arm Vertical	mm	800/900	800/900
副臂上下 Sub-arm Vertical	mm	---	850/950
前后(主臂,副臂) Crosswise (M,S)	mm	主臂/M 245~800 副臂/S 170~585	主臂/M 385~800 副臂/S 170~585
走行 Traverse	mm	1400/1600	
■ 本体重量 Net Weight			
本体 Main Body	Kg	265	289
操作盒 Pendant	Kg	1.6	

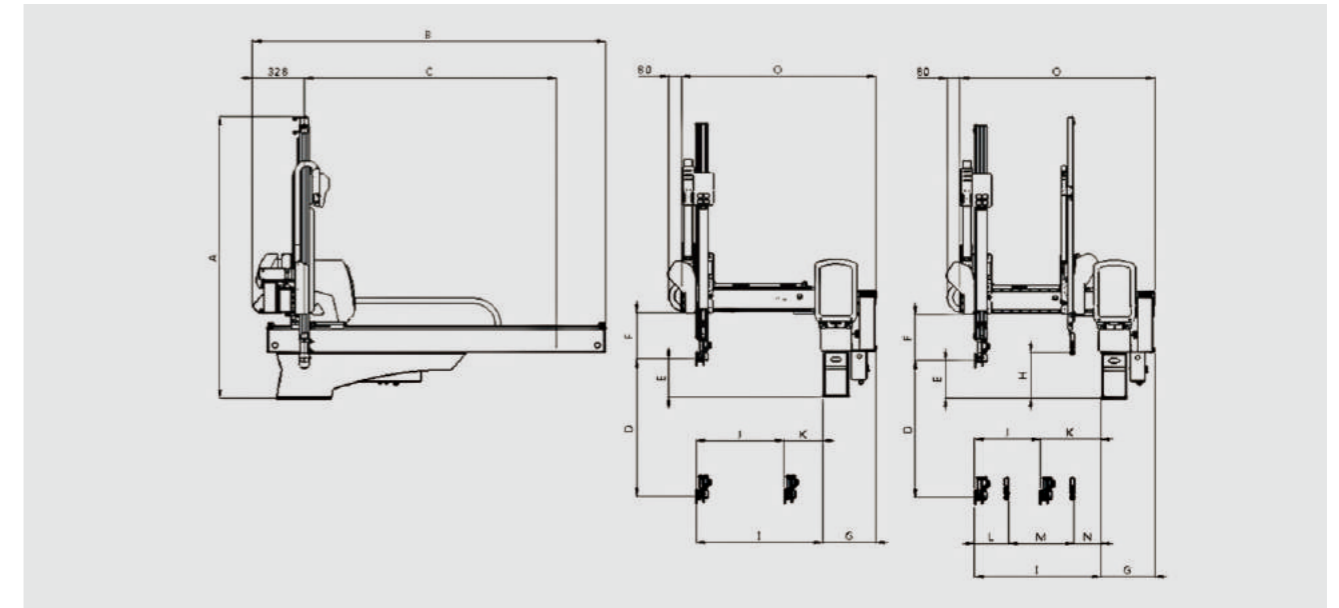

### 外形尺寸 OUTER DIMENSIONS

		EU-80	EU-80s
A	总高 Overall height	1700 (1800)mm	1750 (1850)mm
B	总长 Overall length	2040 (2240) mm	
C	走行行程 Traverse stroke	1400 (1600) mm	
D	主臂上下行程 Main-arm vertical stroke	800 (900) mm	
E	主臂上下待机 Main-arm vertical standby	250 mm	
F	夹具安装有效空间 Bottom of crosswise to chuck mount position	300 mm	
G	基座里侧面-箱体末端 Base side face-Box end	340 mm	
H	副臂上下待机 Sub-arm Vertical standby	---	300 mm
I	主臂前进最大值 Main-arm reach max	800 mm	
J	主臂前进最大行程 Main-arm crosswise stroke max	555 mm	415 mm
K	主臂前后待机最小值 Main-arm crosswise standby min	245 mm	385 mm
L	主副臂接近最小值 Main/Sub-arm proximity min	---	215 mm
M	副臂前进最大行程 Sub-arm crosswise stroke max	---	415 mm
N	副臂前后待机最小值 Sub-arm crosswise standby min	---	170 mm
O	前后臂末端-箱体末端 Crosswise arm end-Box end	1235 mm	

● 当尺寸C是1400mm时, 尺寸B为2040mm  
• when dimension C is 1400mm, B is 2040mm

● 当机械手为三轴时, 尺寸D是800mm时, 尺寸A为1700mm  
• When the manipulator is triaxial and D is 800, dimension A is 1700.

● 当机械手为五轴时, 尺寸D是800mm时, 尺寸A为1750mm  
• When the manipulator is five axis and D is 800, dimension A is 1750.

● 当尺寸C是1600mm时, 尺寸B为2240mm  
• when dimension C is 1600mm, B is 2240mm

● 当机械手为三轴时, 尺寸D是900mm时, 尺寸A为1800mm  
• When the manipulator is triaxial and D is 900, dimension A is 1800.

● 当机械手为五轴时, 尺寸D是900mm时, 尺寸A为1850mm  
• When the manipulator is five axis and D is 900, dimension A is 1850.

### 选项功能 OPTION FUNCTION

- ◆ 夹具内剪刀回路  
Air nipper in chuck circuit
- ◆ NT剪切·可动侧  
NT gate cutting on crossmember of moving
- ◆ 吸着确认4回路  
Additional vacuum sensing unit (4 circuits)
- ◆ 制品夹取4回路  
Product gripping 4 circuits
- ◆ 上升途中闭模  
Mold close during ascend
- ◆ 回转单元  
Rotation unit
- ◆ 顶针后退连动  
Ejector return link
- ◆ 欧规12  
EUROMAP12
- ◆ 欧规67  
EUROMAP 67