

注塑用机械手
TAKE-OUT ROBOT

EUW-120
EUW-120s



标准功能 STANDARD FUNCTION

- 装箱动作 (各轴256点)
Packaging motion (Max. 256 points)
- 自由装箱点 (115点 × 2处)
Free packaging motion (115points × 2stage)
- 取出侧前进姿势控制
Forward and rotate at removing side
- 走行途中姿势
Posture control during traverse
- 落下测下降途中姿势
Posture midway descent at release side
- 顶针连动
Ejector link
- 不良品排出回路
Defective product reject circuit
- 初期不良品排出回路
Initial defective product reject circuit
- 取下降待机
Delayed arm descent
- 胶口途中开放 (去程, 返程)
Midway runner release (Move, Revert)
- 水口模内开放
Runner release within mold
- 吸着确认单元 (2回路)
Additional vacuum sensing unit (2 circuit)
- 横走行待机
Delayed traverse
- 滑移取出回路
Undercut extract circuit
- 输送带启动信号
Start signal of conveyor
- 内部存储记忆 (最大100种类型)
Internal memory (for Max 100 molds)
- 设定值锁定功能
Lock function of setting value
- 固定可动切换
Extraction from fixed mold
- 2国语言切换 (中文, 英文)
Two language exchange (Chinese/English)

型式 MODEL	单位 UNIT	EUW-120	EUW-120s
电源 Power Source	V	AC 200~220 ± 10% 50/60Hz	
最大消费电力 Max Power Consumption	KW	2.35	3.5
使用气压 Air Pressure	Mpa	0.5~0.7	
空气消费量 Air Consumption	Nl/cycle	9.7	
驱动方式 Drive System	---	伺服马达 / AC Servo Motor	
姿势 (气缸) Posture (Air Cylinder)	---	90°固定 / 90°Fixed	
■ 气缸推力 (气压0.49MPa时) Air Cylinder Driving Force (Air Pressure at 0.49MPa)			
最大可搬重量 Max.Load	Kg	8 【含夹具重量 / Incl Chuck Weight】	
姿势力矩 Posture Torque	N · m	25.8	
■ 行程 Stroke			
主臂上下 Main-arm Vertical	mm	1200/1400	1200/1400
副臂上下 Sub-arm Vertical	mm	---	1250/1450
前后(主臂,副臂) Crosswise (M,S)	mm	主臂/M 280~1200	主臂/M 515~1200 副臂/S 265~950
走行 Traverse	mm	1800	
■ 本体重量 Net Weight			
本体 Main Body	Kg	567	613
操作盒 Pendant	Kg	1.6	

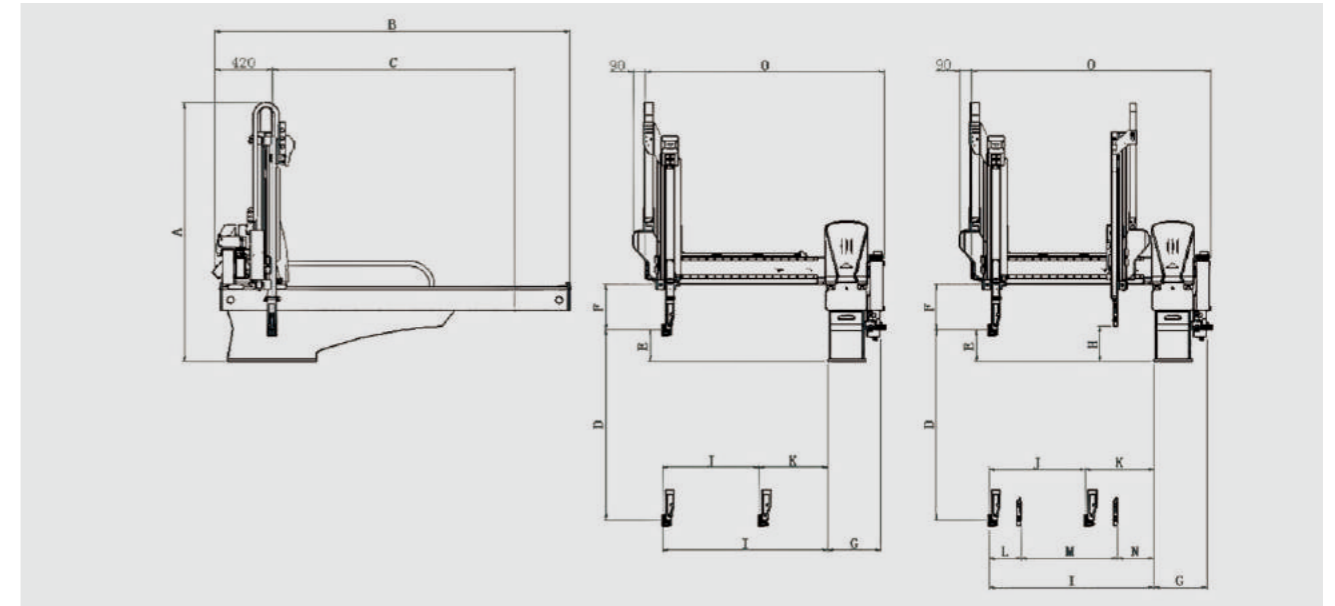

外形尺寸 OUTER DIMENSIONS

EUW-120 EUW-120s

外形尺寸	EUW-120	EUW-120s
A 总高 Overall height	1890 (1950) mm	
B 总长 Overall length	2600 mm	
C 走行行程 Traverse stroke	1800 mm	
D 主臂上下行程 Main-arm vertical stroke	1200 (1400) mm	
E 主臂上下待机 Main-arm vertical standby	230 mm	
F 夹具安装有效空间 Bottom of crosswise to chuck mount position	325 mm	
G 基座里侧面-箱体末端 Base side face-Box end	405 mm	
H 副臂上下待机 Sub-arm Vertical standby	---	280 mm
I 主臂前进最大值 Main-arm reach max	1200mm	
J 主臂前进最大行程 Main-arm crosswise stroke max	800 mm	685mm
K 主臂前后待机最小值 Main-arm crosswise standby min	280 mm	515 mm
L 主副臂接近最小值 Main/Sub-arm proximity min	---	250mm
M 副臂前进最大行程 Sub-arm crosswise stroke max	---	685mm
N 副臂前后待机最小值 Sub-arm crosswise standby min	---	265 mm
O 前后臂末端-箱体末端 Crosswise arm end-Box end	1740 mm	

- 当尺寸C是1200mm时, 尺寸B为1890mm
- when dimension C is 1200mm, B is 1890mm

- 当尺寸C是1400mm时, 尺寸B为1950mm
- when dimension C is 1400mm, B is 1950mm

选项功能 OPTION FUNCTION

- ◆ 夹具内剪刀回路
Air nipper in chuck circuit
- ◆ NT剪切·可动侧
NT gate cutting on crossmember of moving
- ◆ 吸着确认4回路
Additional vacuum sensing unit (4 circuits)
- ◆ 制品夹取4回路
Product gripping 4 circuits
- ◆ 上升途中闭模
Mold close during ascend
- ◆ 回转单元
Rotation unit
- ◆ 顶针后退连动
Ejector return link
- ◆ 欧规12
EUROMAP12
- ◆ 欧规67
EUROMAP 67