

注塑用机械手 TAKE-OUT ROBOT

**MEWE-80
MEWE-80s**

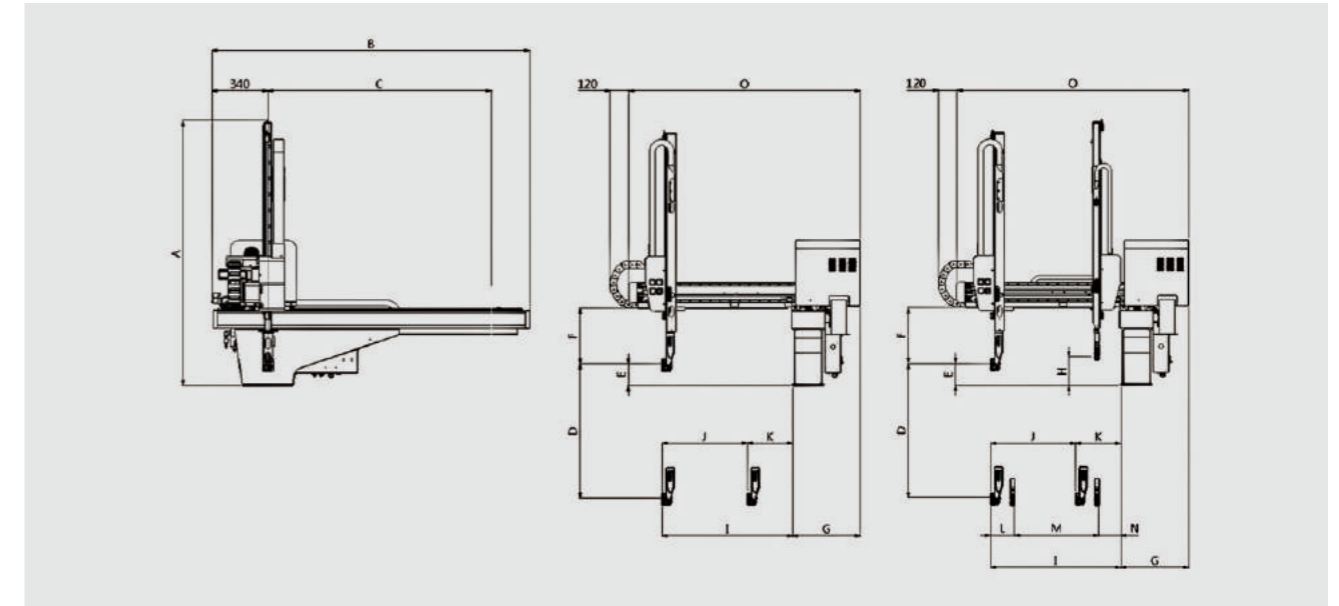
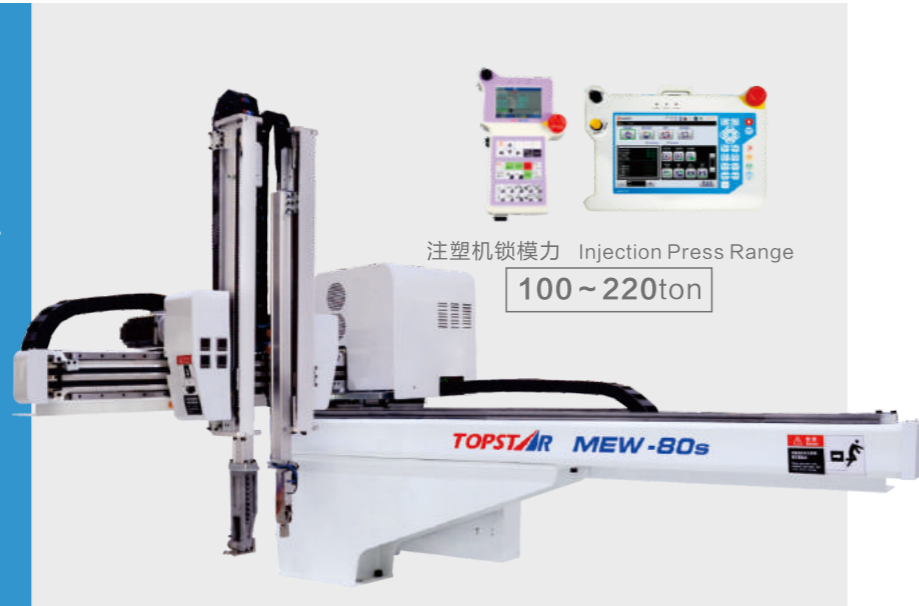

标准功能 STANDARD FUNCTION

- 装箱动作 (各轴256点)
Packaging motion (Max. 256 points)
- 自由装箱点 (115点 × 2处)
Free packaging motion (115points × 2stage)
- 取出侧前进姿势控制
Forward and rotate at removing side
- 走行途中姿势
Posture control during traverse
- 落下测下降途中姿势
Posture midway descent at release side
- 顶针连动
Ejector link
- 不良品排出回路
Defective product reject circuit
- 初期不良品排出回路
Initial defective product reject circuit
- 取向下降待机
Delayed arm descent
- 胶口途中开放 (去程, 返程)
Midway runner release (Move, Revert)
- 水口模内开放
Runner release within mold
- 吸着确认单元 (2回路)
Additional vacuum sensing unit (2 circuit)
- 横走行待机
Delayed traverse
- 滑移取出回路
Undercut extract circuit
- 输送带启动信号
Start signal of conveyor
- 内部存储记忆 (最大100种类型)
Internal memory (for Max 100 molds)
- 设定值锁定功能
Lock function of setting value
- 固定可动切换
Extraction from fixed mold
- 2国语言切换 (中文, 英文)
Two language exchange (Chinese/English)

型式 MODEL 单位 UNIT MEWE-80 MEWE-80s

电源 Power Source	V	AC 220 ± 10% 50/60Hz	
最大消费电力 Max Power Consumption	KW	1.55	2.35
使用气压 Air Pressure	Mpa	0.5 ~ 0.7	
空气消费量 Air Consumption	NI/cycle	2.9	
驱动方式 Drive System	---	伺服马达 / AC Servo Motor	
姿势 (气缸) Posture (Air Cylinder)	---	90°固定 / 90°Fixed	
■ 气缸推力 (气压0.49MPa时) Air Cylinder Driving Force (Air Pressure at 0.49MPa)			
最大可搬重量 Max.Load	Kg	3【含夹具重量 / Incl Chuck Weight】	
姿势力矩 Posture Torque	N · m	10.1	
■ 行程 Stroke			
主臂上下 Main-arm Vertical	mm	900	900
副臂上下 Sub-arm Vertical	mm	---	900
前后(主臂,副臂) Crosswise (M,S)	mm	主臂/M 100 ~ 740	主臂/M 290 ~ 740 副臂/S 165 ~ 615
走行 Traverse	mm	1400 (1600)	
■ 本体重量 Net Weight			
本体 Main Body	Kg	250	
操作盒 Pendant	Kg	1.6	

外形尺寸 OUTER DIMENSIONS MEWE-80 MEWE-80s

A	总高 Overall height	1300mm	
B	总长 Overall length	1920(2100)mm	
C	走行行程 Traverse stroke	1400(1600)mm	
D	主臂上下行程 Main-arm vertical stroke	900mm	
E	主臂上下待机 Main-arm vertical standby	110mm	
F	夹具安装有效空间 Bottom of crosswise to chuck mount position	335mm	
G	基座里侧面-箱体末端 Base side face-Box end	400 mm	
H	副臂上下待机 Sub-arm Vertical standby	---	160 mm
I	主臂前进最大值 Main-arm reach max	740 mm	
J	主臂前进最大行程 Main-arm crosswise stroke max	630 mm	400 mm
K	主臂前后待机最小值 Main-arm crosswise standby min	100 mm	290 mm
L	主副臂接近最小值 Main/Sub-arm proximity min	---	130 mm
M	副臂前进最大行程 Sub-arm crosswise stroke max	---	400 mm
N	副臂前后待机最小值 Sub-arm crosswise standby min	---	180 mm
O	前后臂末端-箱体末端 Crosswise arm end-Box end	1375 mm	

- 当尺寸C是1400mm时, 尺寸B为1920mm
- when dimension C is 1400mm, B is 1920mm

- 当尺寸C是1600mm时, 尺寸B为2100mm
- when dimension C is 1600mm, B is 2100mm

选项功能 OPTION FUNCTION

- ◆ 夹具内剪刀回路
Air nipper in chuck circuit
- ◆ NT剪切·可动侧
NT gate cutting on crossmember of moving
- ◆ 吸着确认2回路
Additional vacuum sensing unit (2 circuits)
- ◆ 制品夹取2回路
Product gripping 2 circuits
- ◆ 吸着确认4回路
Additional vacuum sensing unit (4 circuits)
- ◆ 制品夹取4回路
Product gripping 4 circuits
- ◆ 上升途中闭模
Mold close during ascend
- ◆ 回转单元
Rotation unit
- ◆ 顶针后退连动
Ejector return link
- ◆ 欧规12
EUROMAP12
- ◆ 欧规67
EUROMAP 67